

USER MANUAL

AGD - 100 FAULT CURRENT MONITORING DEVICE

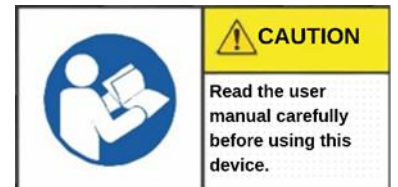

CONTENTS

1) GENERAL INFORMATION ABOUT THE DEVICE	1
1.1 GENERAL.....	1
1.2 INPUTS AND OUTPUTS.....	1
1.3 HMI TOUCH PANEL AND INDICATORS	1
1.4 FUNCTIONS	1
1.5 COMPATIBILITY	2
2) POWER SUPPLY, INPUTS AND OUTPUTS	2
2.1 POWER SUPPLY.....	2
2.2 ANALOG INPUTS.....	2
2.3 DIGITAL INPUTS	2
2.4 RELAY OUTPUTS	2
3) OPERATOR PANEL	3
3.1 SYSTEM SCREEN.....	3
3.2 ALARM SCREEN	4
3.3 SETUP / PARAMETER SCREEN	4
4) PARAMETERS	5
5) PARAMETERS CONFIGURATION.....	14
5.1 DATE AND TIME SETTINGS	15
6) ALARMS.....	16
7) MODBUS RTU	16
8) CONNECTION DIAGRAM	17
9) PHYSICAL DIMENSIONS.....	18

1) GENERAL INFORMATION ABOUT THE DEVICE

The AGD-100 device, manufactured by INOTEL, is designed to detect faults occurring in Medium and High Voltage networks. The current value is measured through current transformers connected to the unit. If the measured current exceeds the adjustable threshold value and detection time, the AGD-100 issues a fault notification. Fault indication is provided via signal LEDs on the AGD-100, which blink according to the type of fault. The device also displays information about the fault type and the time of occurrence on its LCD screen. An external signal lamp blinks during every fault event to visually indicate the presence of a fault.

The AGD-100 can be examined under the following headings:

1.1 GENERAL

- Microprocessor – Based Digital Control
- AGD-100 Power Supply: 20–160 VDC
- Data Communication via MODBUS RTU Protocol
- Operating Temperature Range: -25°C to +55°C
- Protection Class: IP30 & IK-07

1.2 INPUTS AND OUTPUTS

- 1 x RS485
- 2 x Digital Input
- 2 x Digital Output
- 1 x Signal Output

1.3 HMI TOUCH PANEL AND INDICATORS

- 2.8" TFT-LCD Color Touch Panel
- Display of Instantaneous Current Values and Fault Indication
- Parameter Configuration
- Real-Time Monitoring and Logging of Alarm Conditions
- Phase Fault and Earth Fault LED Indicators (LED indicators are directly linked to the control system independently from the HMI panel. In case of HMI screen failure, status monitoring can still be performed via the LEDs.)

1.4 FUNCTIONS

- Activation of Selected Contacts in the Event of a Phase Fault
- Activation of Selected Contacts in the Event of an Earth Fault
- Activation of Selected Contacts in the Event of a Phase or Earth Fault
- Fault Indication via HMI Screen and Signal Lamp

1.5 COMPATIBILITY

- TS EN 60068-2-1
- TS EN 60068-2-1
- TS EN 60068-2-14
- TS EN 60068-2-30
- TS EN 60068-2-78
- TS 3033 EN 60529
- TS EN 62262
- TS EN-60255-27
- TS EN 61000-4-2
- TS EN 61000-4-3
- TS EN 61000-4-4
- TS EN 61000-4-5
- TS EN 61000-4-6
- TS EN 61000-4-8

2) POWER SUPPLY, INPUTS AND OUTPUTS

2.1 POWER SUPPLY

The AGD-100 operates with a DC voltage in the range of 20–160 V. It includes internal protection against short circuits and overvoltage.

2.2 ANALOG INPUTS

The AGD-100 is equipped with 3 analog inputs. Clamp-on type current transformers are connected to these inputs.

2.3 DIGITAL INPUTS

The AGD-100 features 2 digital inputs. These inputs can be used for remote alarm reset or device restart functions.

2.4 RELAY OUTPUTS

The AGD-100 provides 2 configurable relay outputs. These relays can be assigned by the user for Phase Fault, Earth Fault, or combined Phase & Earth Fault notifications.

3) OPERATOR PANEL

The operator panel is used for monitoring real-time current values in the AGD-100 fault indication system. It features a 2.8" TFT-LCD screen, through which fault notifications are displayed and communication parameters can be modified.

3.1 SYSTEM SCREEN

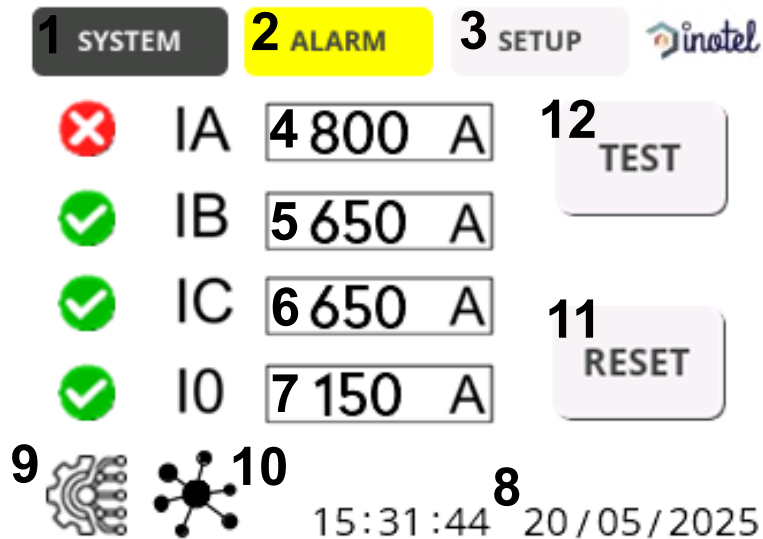

Figure 1. Device Main Screen

- 1,2,3: “SYSTEM”, “ALARM” and “SETUP” screen navigation buttons,
- 4,5,6: Measured phase current values,
- 7: Earth current value,
- 8: Date and time information,
- 9: Indicates that the device has internal communication,
- 10: Indicates the MODBUS communication status of the device,
- 11: The “RESET” button returns the device to normal operating mode,
- 12: The “TEST” button is used to check whether the relays, internal LEDs, and signal lamp are functioning properly. When the test button is pressed, the relays are activated, and the signal lamp and panel LEDs flash.

Note: When a fault is detected, the “ALARM” button turns into a red-colored button as shown in Figure 1.

3.2 ALARM SCREEN

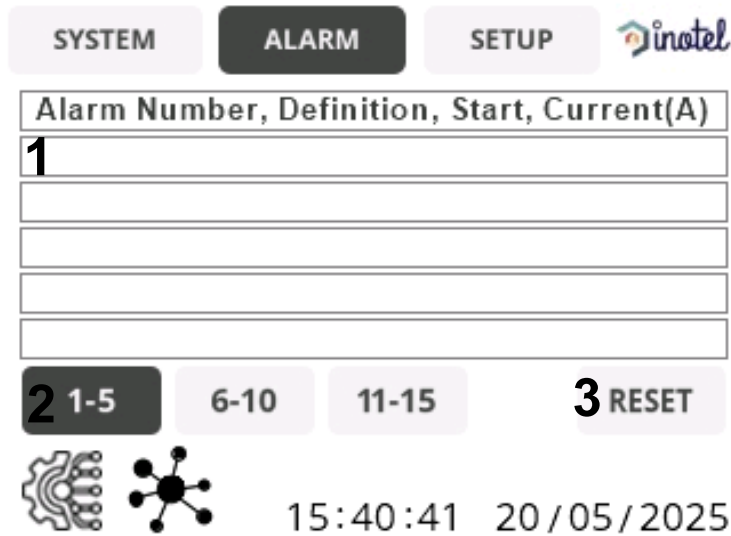

Figure 2. Device Alarm Screen

- 1: Alarm display screen (It is designed to list 5 alarms on each tab.)
- 2: The device can store up to 15 alarms in total. These buttons allow navigation between pages.
- 3: Alarm clear button. (If there is no active alarm, this button clears all stored alarm information. If an active alarm is present, pressing the button displays the most recent alarm.)

3.3 SETUP / PARAMETER SCREEN

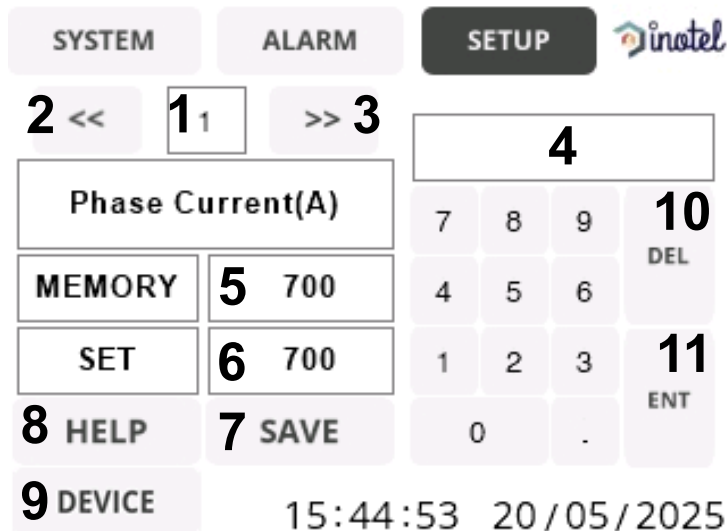

Figure 3. Device Settings Screen

- 1: Indicates the current parameter index,
- 2,3: Navigate to the previous or next parameter,
- 4: The value to be set is entered in this field,

- 5: Displays the value stored in the device's memory,
- 6: The **"SET"** value is assigned to the **"MEMORY"** value by pressing the **"SAVE"** button.
- 7: The **"SAVE"** button stores the **"SET"** value as the **"MEMORY"** value and writes it to non-volatile memory.
- 8: Opens the information screen related to the selected parameter in the menu.
- 9: Opens the menu for date, time, and screen brightness settings.
- 10: Deletes the entered value.
- 11: Confirms and enters the desired value into the **"SET"** field.

4) PARAMETERS

The determination of parameters for the AGD-100 Power Network Monitoring and Protection Relay shall be based on the values and limits specified below.

4.1 PHASE CURRENT

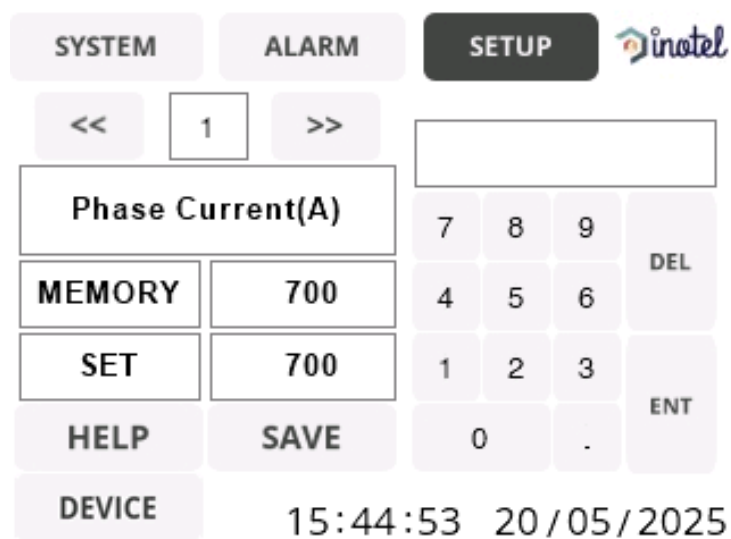

Figure 4. Phase Current

- Indicates the phase fault threshold value. A maximum value of 1000 can be entered.

4.2 EARTH CURRENT

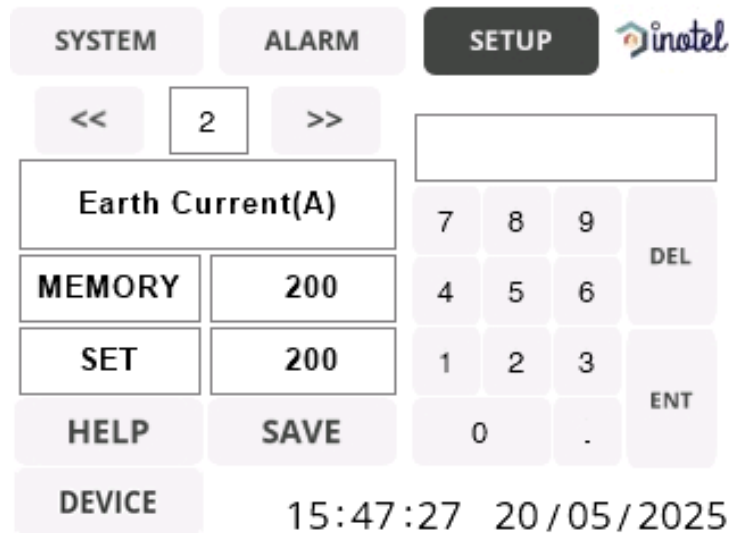

Figure 5. Earth Current

- Indicates the earth fault threshold value. A maximum value of 500 can be entered.

4.3 PHASE DETECTION TIME

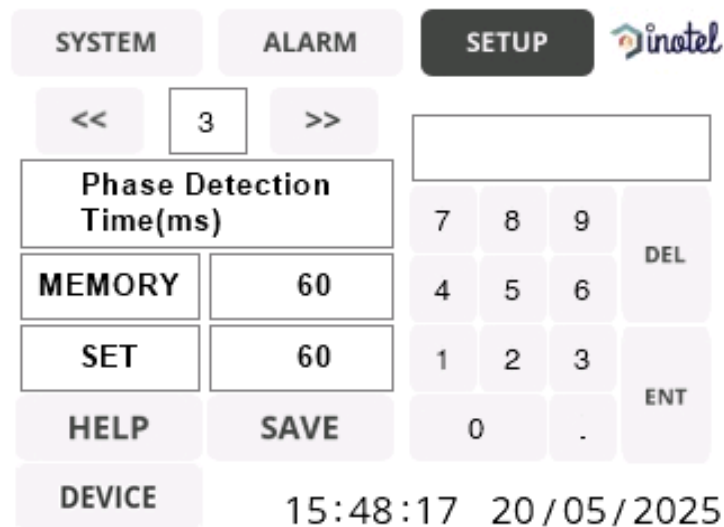

Figure 6. Phase Detection Time

- Represents the phase fault detection time. A minimum value of 20 must be entered.

4.4 EARTH DETECTION TIME

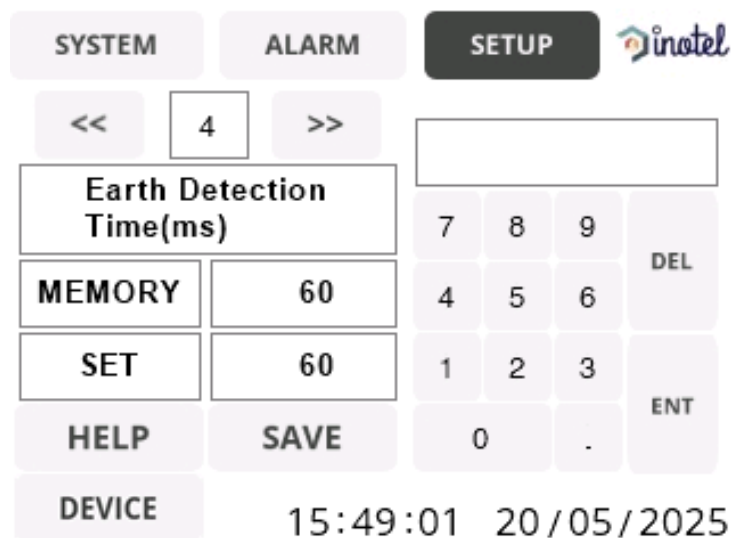

Figure 7. Earth Detection Time

- Represents the earth fault detection time. A minimum value of 20 must be entered.

4.5 AUTOMATIC RESET TIME

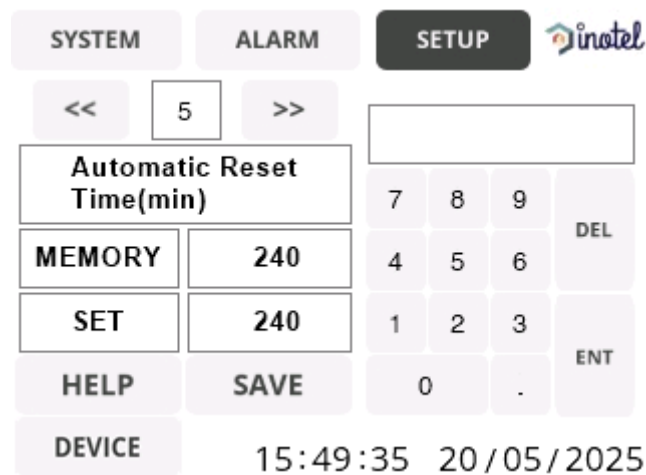

Figure 8. Automatic Reset Time

- Represents the automatic reset time. The device will reset itself after the set time, even if a fault condition persists.

4.6 CURRENT RESET

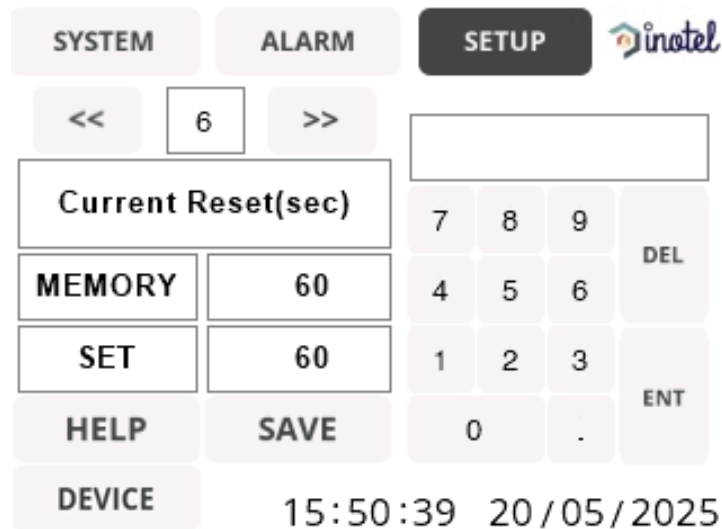

Figure 9. Current Reset

- Represents the reset time after power is restored following a fault clearance.

4.7 INRUSH CURRENT DURATION

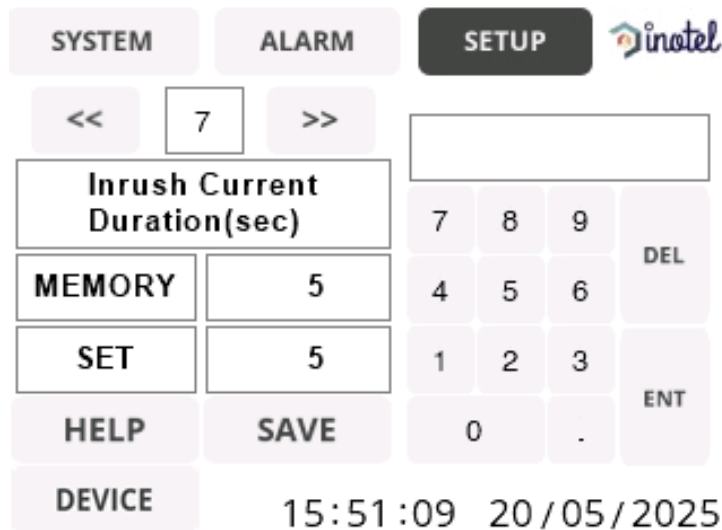

Figure 10. Inrush Current Duration

- Represents the inrush time. A minimum value of 1 must be entered.

4.8 CURRENT TRANSFORMER RATIO

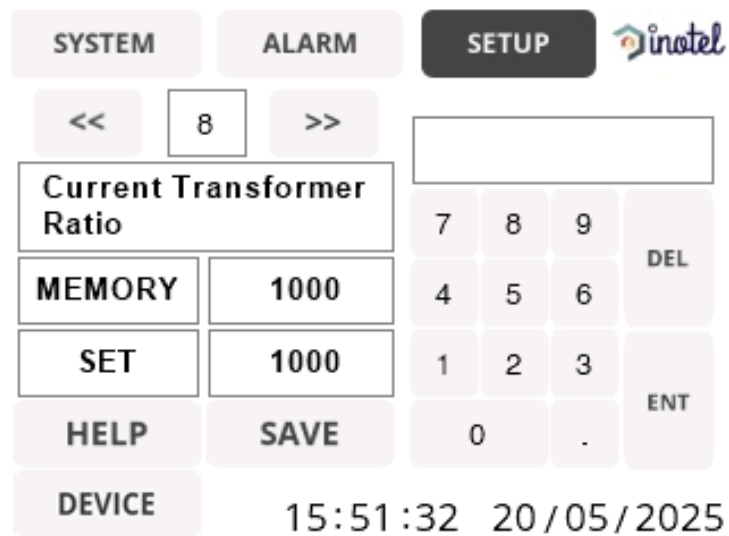

Figure 11. Current Transformer Ratio

- The current transformer ratio connected to the device must be entered.

4.9 DIGITAL INPUT 1

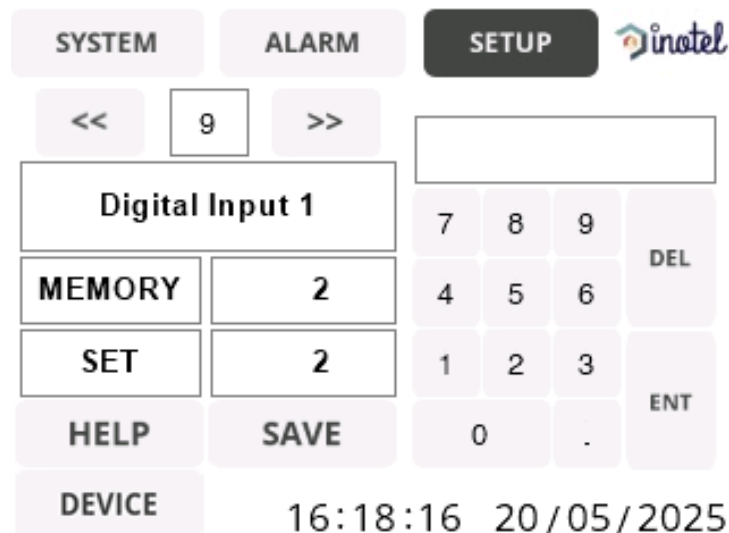

Figure 12. Digital Input 1

- Digital Input 1 Parameters;
0 = Disabled,
1 = Used to Reset Alarms,
2 = Used to Remotely Reset The Device.

4.10 DIGITAL INPUT 2

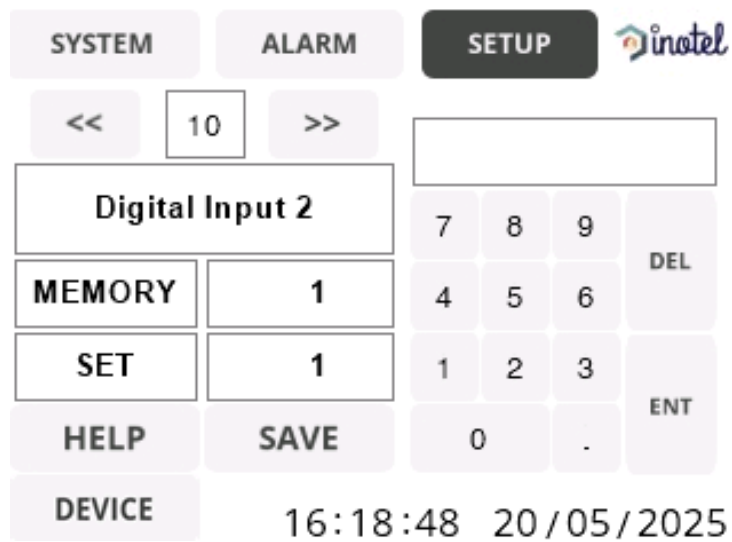

Figure 13. Digital Input 2

- Digital Input 2 Parameters;
0 = Disabled,
1 = Used for Resetting Alarms,
2 = Used for Remotely Resetting The Device.

4.11 LED OUTPUT

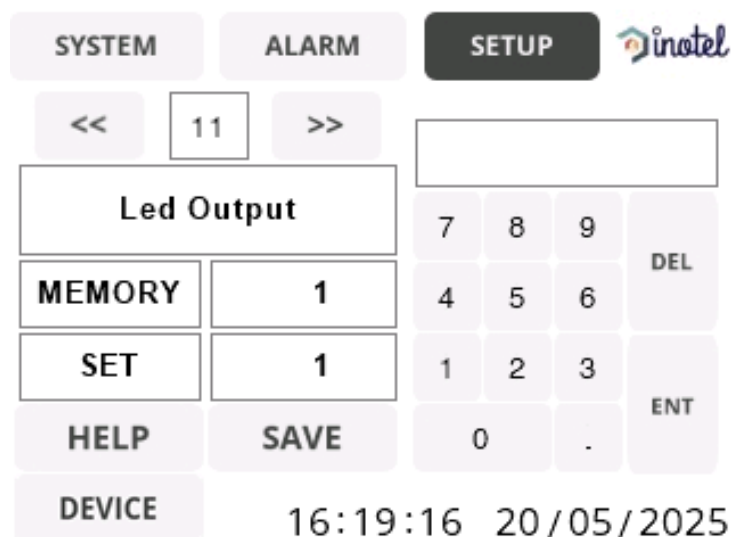

Figure 14. Led Output

- The signal lamp is active when set to 1 and provides fault indication to the user. If set to 0, it remains inactive.

4.12 DIGITAL OUTPUT 1

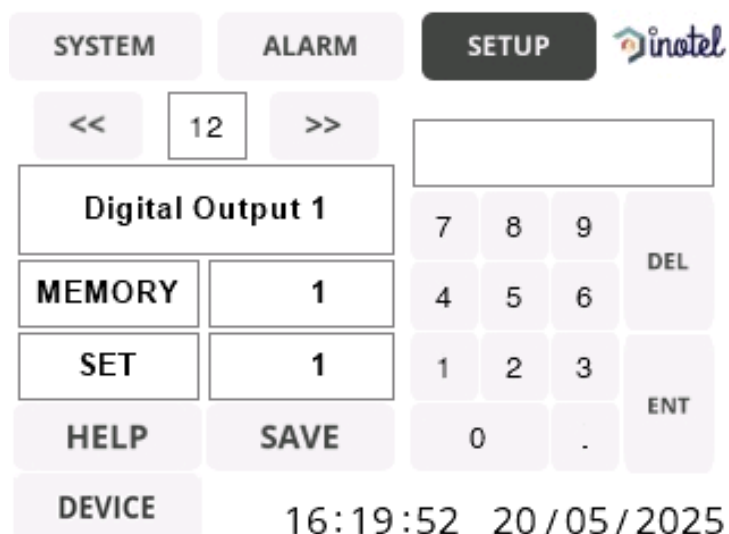

Figure 15. Digital Output 1

- Digital Output 1 Parameters;
 - 0 = No Response,
 - 1 = Provides Contact Output on Phase Fault,
 - 2 = Provides Output on Earth Fault,
 - 3 = Provides Output on Both Fault.

4.13 DIGITAL OUTPUT 2

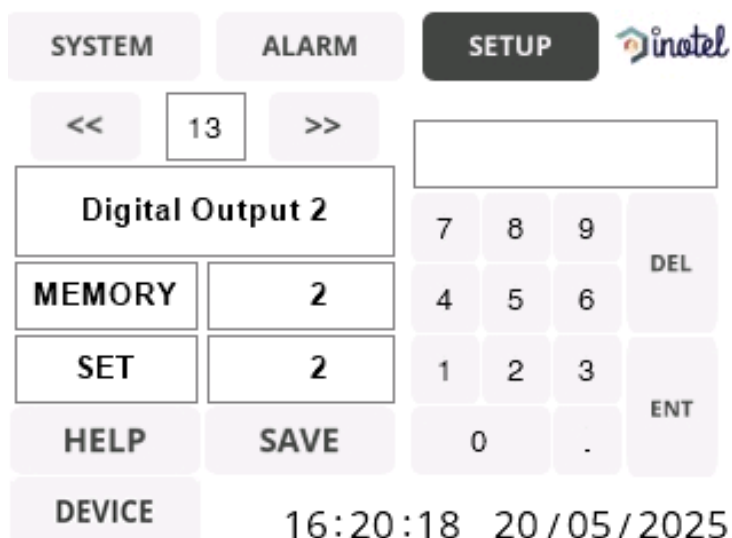

Figure 16. Digital Output 2

- Digital Output 2 Parameters;
 - 0 = No Response,
 - 1 = Provides Contact Output on Phase Fault,
 - 2 = Provides Output on Earth Fault,
 - 3 = Provides Output on Both Fault.

4.14 PASSWORD

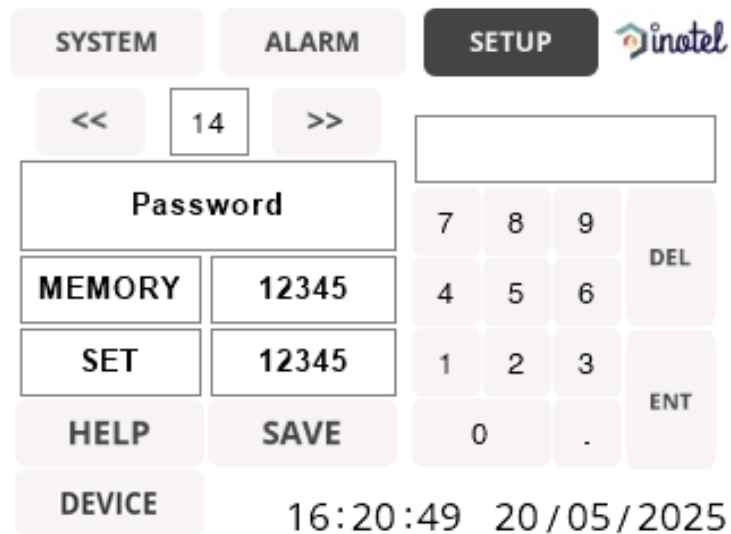

Figure 17. Password

- User password. The default value is 12345.

4.15 MODBUS ID

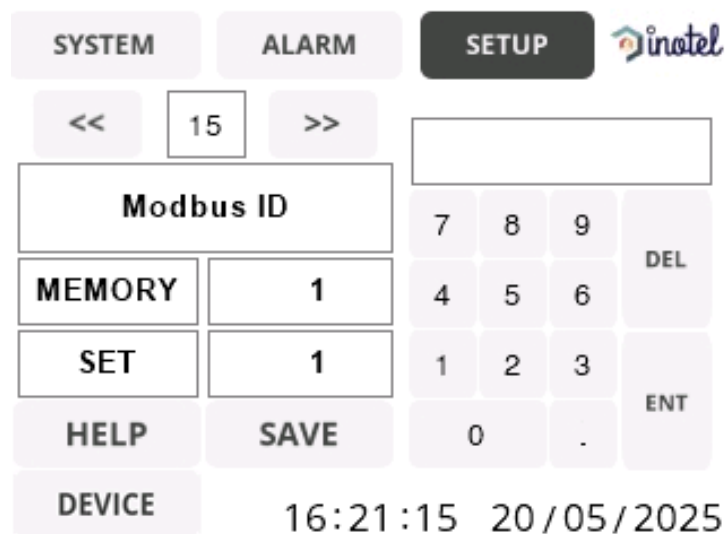

Figure 18. Modbus ID

- AGD – 100 Modbus ID parameter. A value between 1 and 247 must be entered.

4.16 BAUD RATE

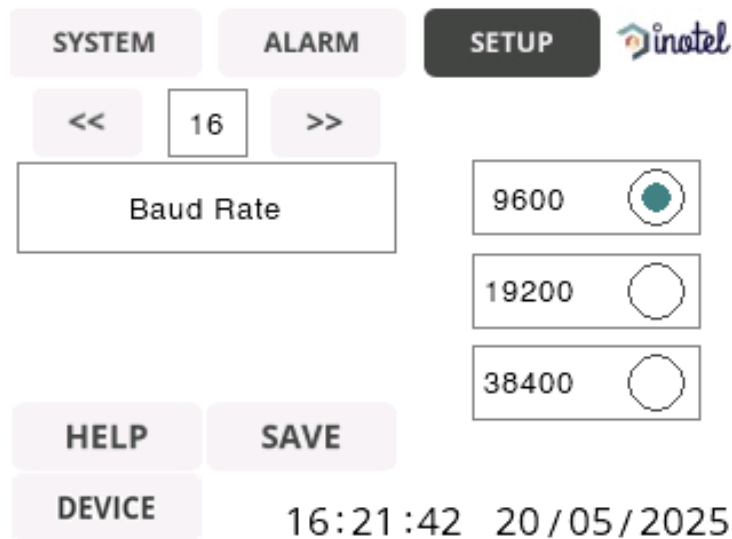

Figure 19. Baud Rate

- In this section, the user can set the device's MODBUS communication speed to one of the following three rates:
 - ✓ 9600 bit / sec
 - ✓ 19200 bit / sec
 - ✓ 38400 bit / sec

4.15 FACTORY RESET

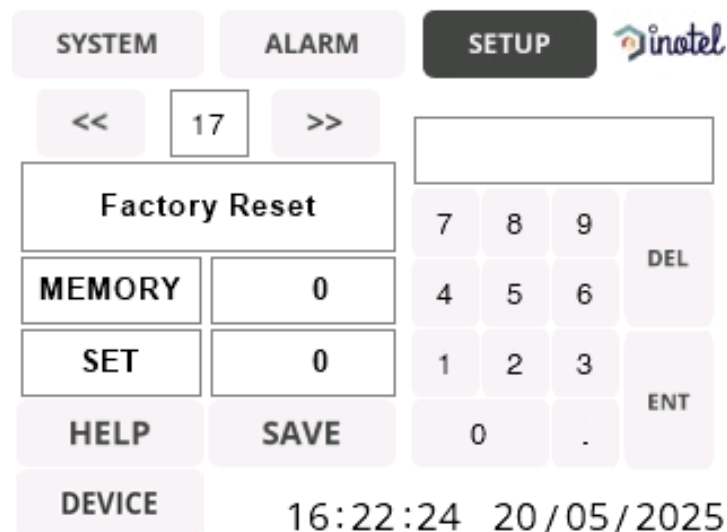

Figure 20. Factory Reset

- In this section, the user can reset the AGD-100 device by setting the parameter to 1, which triggers the device reset.

5) PARAMETERS CONFIGURATION

- AGD – 100 arıza gösterge düzeneğinin parametrelerinin set edilmesi için aşağıdaki sistem ekranı fotoğrafının sağ üstünde görülen “**SETUP**” kısmına basılır.

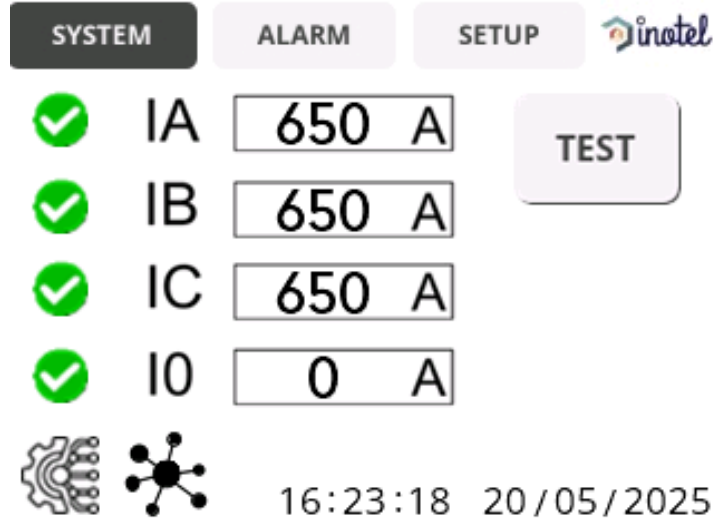

Figure 21. Parameters Configuration

- Then, enter the user password of the AGD-100 fault indicator device in the “**PASSWORD**” field as shown below.



Figure 22. Parameters Configuration

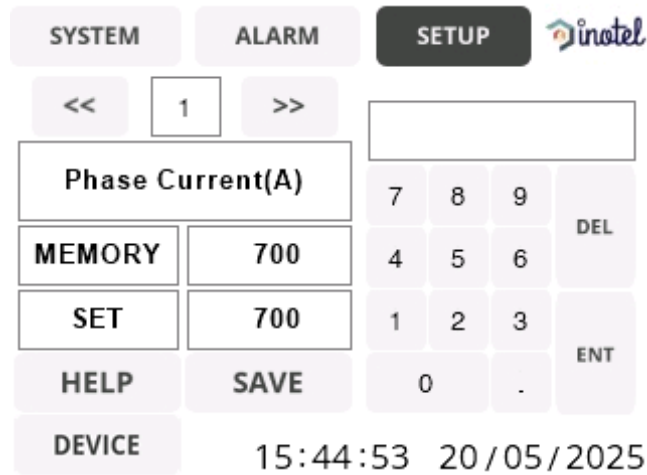

Figure 23. Parameters Configuration

- After logging in, the user selects the parameter to be changed. The desired parameter value is entered using the number keys on the right, then the “**ENT**” button is pressed. The entered value is first saved in the “**SET**” section. Next, the “**SAVE**” button is clicked. Finally, the entered parameter value is stored in the “**MEMORY**” section. This value becomes the latest parameter stored in the device’s memory.

5.1 DATE AND TIME SETTINGS

- To adjust the date, time, and screen brightness, click the “**DEVICE**” button located on the “**SETUP**” page.

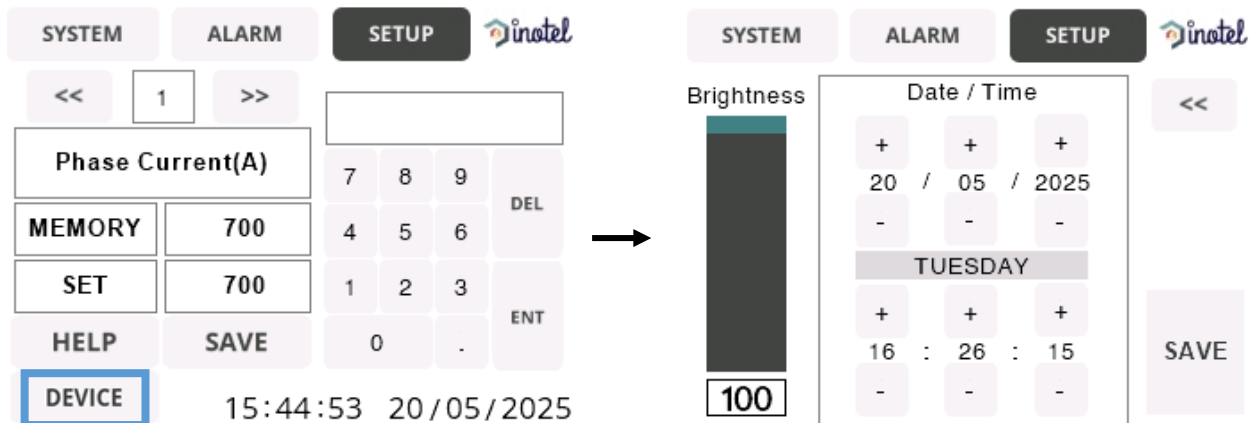

Figure 24. Date and Time Settings

- To adjust the time and date settings, use the “+” and “-” buttons to set the desired values. To adjust the screen brightness, use the slider on the left.

6) ALARMS

- The fault current indicator device detects phase and ground current faults in underground networks. These faults are displayed as alarm currents in four different types:
 - ✓ **IA Phase Fault:**
Indicates that the current in Phase A has exceeded the phase fault threshold value (Phase Current).
 - ✓ **IB Phase Fault:**
Indicates that the current in Phase B has exceeded the phase fault threshold value (Phase Current).
 - ✓ **IC Phase Fault:**
Indicates that the current in Phase C has exceeded the phase fault threshold value (Phase Current).
 - ✓ **I0 Earth Fault:**
Indicates that the ground current has exceeded the earth fault threshold value (Earth Current).

7) MODBUS RTU

The AGD-100 operates with function codes 0x04 and 0x05. Using function code 0x04, it allows real-time values defined on the parameter page to be read via the MODBUS RTU protocol, according to the specified MODBUS ID. The data can be read from starting address 0 to ending address 21. Function code 0x05 allows remote reset operations. The UART (Universal Asynchronous Receiver Transmitter) parameters defined for MODBUS communication are as follows:

- Baudrate : 9600 bit/s
- Parity : None
- Data Bit : 8
- Stop Bit : 1

The MODBUS Register (MODBUS Data Map) is shown in the table below. The table values are represented as unsigned 16-bit integers. Analog measurement data is stored by multiplying the actual value by a factor of 10. Counter values are stored as positive integers. Alarm information is stored as logical (boolean) values. If function code 0x05 is used and the High bit is sent as 0xFF, the device enters the reset state.

FUNCTION	ADRESS	EXPLANATION
0X04	0	IA*10
0X04	1	Spare
0X04	2	IB*10
0X04	3	Spare
0X04	4	IC*10

0X04	5	Spare
0X04	6	I0*10
0X04	7	Spare
0X04	8	Kontak1 Durum *10
0X04	9	Spare
0X04	10	Kontak2 Durum *10
0X04	11	Spare
0X04	12	IA Phase Fault*10
0X04	13	Spare
0X04	14	IB Phase Fault*10
0X04	15	Spare
0X04	16	IC Phase Fault*10
0X04	17	Spare
0X04	18	I0 Earth Fault*10
0X04	19	Spare
0X04	20	Number of Faults*10

8) CONNECTION DIAGRAM

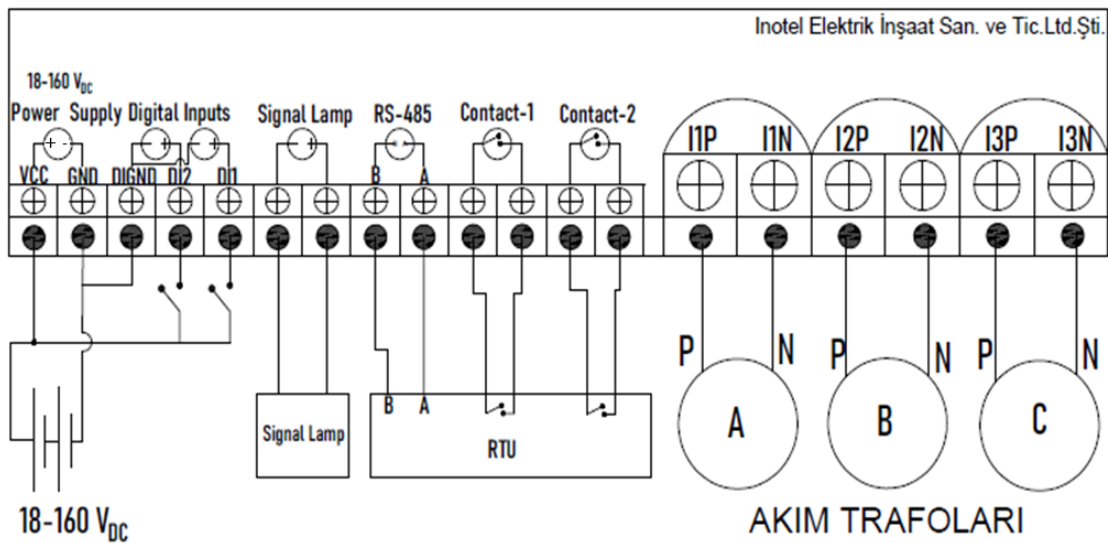

Figure 25. Connection Diagram

The AGD-100 connections must be made as shown in the diagram, and polarity must be observed carefully.

9) PHYSICAL DIMENSIONS



Figure 26. Physical Dimensions

The AGD-100 has dimensions of **72 x 144 x 108 mm** (Width x Height x Depth) and is housed in a DIN rail-mountable plastic enclosure.



Ostim, Turan ıđdem Cd,
No:7,06374 Ostim
OSB/Yenimahalle/ANKARA



0312 750 09 18



<https://www.inotelek.co>